

REACTIVE POWER OPTIMIZATION WITH SVC & TCSC USING GENETIC ALGORITHM

Biplab BHATTACHARYYA, Vikash Kumar GUPTA, Sanjay KUMAR

Department of Electrical Engineering, Indian School of Mines, Dhanbad, 826004 Jharkhand, India

biplabrec@yahoo.com, vikash1146@gmail.com, sanjayism2012@gmail.com

Abstract. *In this paper Genetic Algorithm (GA) is used as an evolutionary techniques for the optimal placement of flexible AC transmission systems (FACTS) devices in an interconnected power system. Here two types of FACTS devices has been discussed namely, Thyristor Controlled Series Capacitor (TCSC) and Static Var Compensator (SVC) for the economic operation and to reduce the transmission loss. Reactively loading of the system is taken from base to 200 % of base loading and the system performance is observed without and with FACTS devices. Optimal placement of FACTS devices in the system is determined by calculating active and reactive power flow in lines. FACTS devices along with reactive generation of generators and transformer tap setting are used for the power transfer capacity using GA. The proposed approach is applied on IEEE 14 and IEEE 30-bus test systems. Finally the effectiveness of the proposed GA based method of placement of FACTS devices is established by comparing the results with another standard method of optimization like Particle Swarm Optimization (PSO) technique.*

Keywords

FACTS devices, genetic algorithm, line power Flow, optimal location of FACTS devices, particle swarm optimization.

1. Introduction

Due to increase in power demand, restriction on the construction of new lines, environment, unscheduled power flows in lines creates congestion in the transmission network and increases transmission loss. Maintenance of bus voltages and line loads within predefined limits is one of the challenging tasks in an interconnected power system. Effective control of reactive compensation on weak nodes improves voltage profile, reduces power loss and improves both steady state & dynamic performance of the system.

Power flow through an ac transmission line is a function of line impedance, the magnitude and the phase angle between the sending end and the receiving end voltages. With the development of FACTS devices both the active and reactive power flow in the lines can be controlled. The concept of flexible AC transmission system (FACTS) was first introduced by Hingorani [1]. FACTS devices are solid-state converters having the capability of control of various electrical parameters in transmission circuits.

Sensitivity analysis and linear programming technique for the optimal location and size of Static Var Compensator (SVC) in a power system is discussed in [2]. Optimization techniques are widely used in the field of technology. Optimal placement of Thyristor Controlled Series Capacitor (TCSC) for increasing loadability and minimizing transmission loss by Genetic Algorithm (GA) is discussed in [3]. Optimal reactive power dispatch along with the setting of switchable series & shunt FACTS devices is presented in [4]. Optimal placement of Var sources by loss sensitivity based method is presented in [5]. A hybrid Genetic Algorithmic approach with FACTS devices for optimal power flow is dealt in [6].

Solution of optimal power flow using GA is presented by Osman et al. in [7]. Authors have discussed Genetic Algorithm based approach for the placement of different types of FACTS devices in [8]. Computational Intelligence based algorithm is presented in [9] to determine the optimal placement and parameter setting of TCSC for enhancing the security of power system under single line contingency.

Concept of comutational intelligence technique using FACTS controller is applied in [10] for the loadability enhancement in a restructured power system. In [11] GA based technique is discussed for the placement of FACTS devices in some test systems. Das et al. in [12] applied GA to minimize active power loss in a radial distribution network using SVC. About the modelling and selection of possible locations for the installation of FACTS devices have been discussed in [13]. An op-

timization method is used in [14] that combines the reliability and the efficiency of radial power distribution systems to reduce the active power loss, through a process of network reconfiguration. Effect of implementation of Genetic Algorithm for the determination of locations and size of the FACTS controller is discussed in [15].

Nomenclature:

- X_{Line} : reactance of line,
- S : operating range of FACTS devices,
- C_{Total} : total cost of system operation,
- $C_1(E)$: cost due to energy loss,
- $C_2(F)$: total investment cost of the FACTS Devices,
- $P_{ni}^{min}, P_{ni}^{max}$: lower and upper limit of nodal active power in the i -th bus respectively,
- P_{ni}, Q_{ni} : nodal active and reactive power output of the i -th bus respectively,
- $Q_{ni}^{min}, Q_{ni}^{max}$: lower and upper limit of nodal reactive power in the i -th bus respectively,
- $Q_{gi}^{min}, Q_{gi}^{max}$: lower and upper limit of existing nodal reactive capacity in the i -th bus respectively,
- Q_{gi} : output of existing nodal reactive capacity in the i -th bus,
- P_{Gi}, Q_{Gi} : active and reactive power generation in the i -th bus respectively,
- P_{Di}, Q_{Di} : active and reactive power consumed by load in the i -th bus respectively,
- P_i, Q_i (inj): real and reactive power flow change takes place at the node i due to TCSC connected to a particular line between the nodes i & j ,
- Q_{iL} (inj): reactive power injection due to SVC,
- V_i, V_j : voltage of i -th and j -th bus respectively,
- N : number of lines,
- G_{ij}, B_{ij} : real and imaginary part of admittance between buses i & j respectively,
- θ_{ij} : phase angle between V_i & V_j ,
- V_i^{gen-1} : current velocity of agent i at previous generation,
- w : weight function for velocity of agent i ,
- $rand$: is the random number between 0 and 1,

- S_i^{gen-1} : current position of agent i at previous generation,
- C_i : weight coefficient for each term,
- p_{besti} : pbest of agent i ,
- g_{besti} : gbest of agent i .

2. FACTS Devices

2.1. FACTS Devices & Cost Functions

Two types of FACTS devices namely thyristor controlled series capacitors (TCSC) and static VAR compensators (SVC) are used in the transmission network:

- TCSC: By modifying the line reactance TCSC acts as either inductive or capacitive compensator. The maximum value of the capacitance is fixed at $-0.8X_{Line}$ and $0.2X_{Line}$ is the maximum value of the inductance.
- The SVC can be operated as either inductive or capacitive compensation. It can be modeled as a fixed capacitor and a thyristor controlled reactor. So the function of the SVC is either to inject reactive power to the bus or to absorb reactive power from the bus where it is connected.

According to [18], cost functions for SVC and TCSC are given below:

- TCSC:

$$C_{TCSC} (\text{US\$/kVar}) = 0.0015 \cdot S^2 - 0.7130 \cdot S + 153.75, \quad (1)$$

- SVC:

$$C_{SVC} (\text{US\$/kVar}) = 0.0003 \cdot S^2 - 0.3051 \cdot S + 127.38. \quad (2)$$

Here, S is the operating range of the FACTS devices.

3. Optimal Placement of FACTS Devices

Having made the decision to install a FACTS device in the system, there are three main issues that are to be considered: types of device, its capacity and location. The decision where they are to be placed is largely dependent on the desired effect and the characteristics of

the specific system. SVC's are mostly suitable when reactive power flow or voltage support is necessary. Also the costs of the devices play an important role for the choice of a FACTS devices. There are two distinct means of placing a FACTS device in the system for the purpose of increasing the system's ability to transmit power, thereby allowing for the use of more economic generating units. That is why FACTS devices are placed in the more heavily loaded lines to limit the power flow in that line. This causes more power to be sent through the remaining portions of the system while protecting the line with the device from being overloaded. This method which sites the devices in the heavily loaded line is the most effective. If reactive power flow is a significant portion of the total flow of the limiting transmission line, either a TCSC device in the line or a SVC device located at the end of the line that receives the reactive power, may be used to reduce the reactive power flow, thereby increasing the active power flow capacity.

4. The Proposed Approach

Here the main objective is to minimize the transmission loss by incorporating FACTS devices at suitable locations of the transmission network. Inclusion of FACTS controllers also increase the system cost. So, optimal placement of FACTS devices is required such that the gain obtained by reducing the transmission loss is significant even after the placement of costly FACTS devices. Installation costs of various FACTS devices and the cost of system operation, namely, energy loss cost are combined to form the objective function to be minimized. The optimal allocation of FACTS devices can be formulated as:

$$C_{\text{total}} = C_1(E) + C_2(F), \quad (3)$$

where $C_1(E)$ is the cost due to energy loss and $C_2(F)$ is the total investment cost of the FACTS devices. Subject to the nodal active and reactive power balance:

$$P_{ni}^{\min} \leq P_{ni} \leq P_{ni}^{\max}, \quad (4)$$

$$Q_{ni}^{\min} \leq Q_{ni} \leq Q_{ni}^{\max} \quad (5)$$

and voltage magnitude constraints:

$$V_i^{\min} \leq V_i \leq V_i^{\max} \quad (6)$$

and the existing nodal reactive capacity constraints:

$$Q_{gi}^{\min} \leq Q_{gi} \leq Q_{gi}^{\max}. \quad (7)$$

Superscripts min, max, are the minimum and maximum limits of the variables. The power flow equations between the nodes i - j after incorporating FACTS devices would appear as:

- TCSC:

$$P_{Gi} - P_{Di} + P_i - \sum_{j=1}^{N-1} V_i V_j (G_{ij} \cos \theta_{ij} + B_{ij} \sin \theta_{ij}) = 0, \quad (8)$$

$$Q_{Gi} - Q_{Di} + Q_{i(\text{inj})} - \sum_{j=1}^{N-1} V_i V_j (G_{ij} \sin \theta_{ij} + B_{ij} \cos \theta_{ij}) = 0, \quad (9)$$

$$Q_{Gj} - Q_{Dj} + Q_j - \sum_{j=1}^{N-1} V_i V_j (G_{jj} \sin \theta_{jj} + B_{jj} \cos \theta_{jj}) = 0, \quad (10)$$

$$Q_{Gj} - Q_{Dj} + Q_{j(\text{inj})} - \sum_{j=1}^{N-1} V_i V_j (G_{jj} \sin \theta_{jj} + B_{jj} \cos \theta_{jj}) = 0, \quad (11)$$

- SVC:

$$Q_{Gi} - Q_{Di} + Q_{iL(\text{inj})} - \sum_{j=1}^{N-1} V_i V_j (G_{ij} \sin \theta_{ij} + B_{ij} \cos \theta_{ij}) = 0. \quad (12)$$

These changes in the power flow equations are taken into consideration by appropriately modifying the bus admittance matrix for execution of load flow in evaluating the objective function for each individual population of generation of both Genetic Algorithm (GA) and Particle Swarm Optimization (PSO) based optimization technique.

In this approach, first the locations of FACTS devices are defined by calculating the power flow in the transmission lines. Here we choose only four locations in IEEE 14 bus and eight locations in IEEE 30 bus system for the placement of FACTS devices. SVC's positions are selected by choosing the lines carrying largest reactive power. In IEEE 14 bus system, 10th, 13th & 14th buses and in IEEE 30 bus system, 21st, 7th, 17th & 15th buses are found as buses where suitable reactive injection by SVC's could improve the system performance. Line number 7th in IEEE 14 bus and lines 25th, 41th, 28th & 5th in IEEE 30 bus system are found as the lines for TCSC's placement and simultaneously series reactance of these lines are controlled.

In the proposed approach combined effect of SVC & TCSC is tested. Simultaneous use of shunt (SVC) and series (TCSC) FACTS controller has a better effect than if either of the FACTS controller used singly. We only can connect SVC at buses where reactive injections are required and also there is a limit of a number of SVC's that can be connected to a particular system. Similarly, modifying line reactance helps greatly in reducing line loss & improving overall system performance. Application of series & shunt combination of FACTS controller on a standard system is analyzed in the present work. We have taken only one number of TCSC and three number of SVC's in IEEE 14 bus

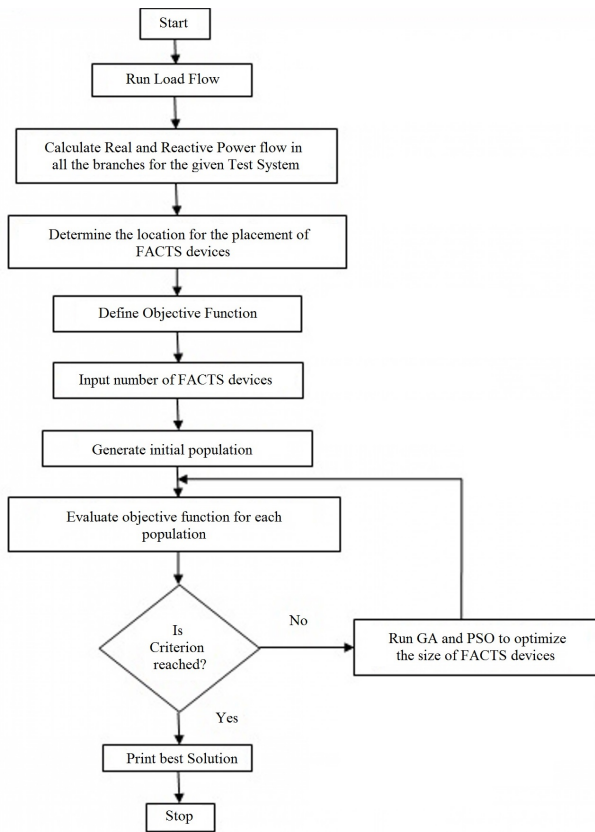

Fig. 1: Flowchart for the proposed approach.

system & four numbers of TCSC's and four numbers of SVC's in IEEE 30 bus system for the purpose of analysis in the present problem. The number of FACTS controller depends also on the size of the system.

Maximum value of SVC is taken as 50 MVAR & maximum value of TCSC is taken as 10 MVAR in the present problem. Fig. 1 shows a flowchart for the proposed approach.

4.1. Genetic Algorithm in the Proposed Method

The function of the GA is to find the optimum value of the different FACTS devices. Here two different types of FACTS devices are used. The locations for the placement of different FACTS devices are determined on the basis of power flow analysis. TCSC's modifies reactance of the lines and SVC's are to control reactive injection at buses.

In addition transformer tap positions along with reactive generations of the generators are controlled. In IEEE 14 bus system there are three transformer tap positions and four generator buses while in IEEE 30 bus system there are four transformer tap positions and five generator buses. So, as a whole all the controlling parameters are to be optimized by Genetic Algo-

rithm [19]. These controlling parameters is represented within a string. This is shown in Tab. 1 for IEEE 14 bus system and in Tab. 2 for IEEE 30 bus system. Initially a population of N strings is randomly created in their limits. Then the objective function is computed for every individual of the population.

A biased roulette wheel is created such a way so that the parameter values are selected according to their fitness obtained after computing the objective function for all the individuals of the current population. Thereafter the usual Genetic operation such as Reproduction, Crossover & Mutation takes place. Two individual are randomly selected from the current population for reproduction. Then crossover takes place with a probability close to one (here 0.8).

Finally mutation with a specific probability (very low) completes one Genetic cycle and individuals of the same population with improved characters are created in the next generation. The objective function is then again calculated for all the individuals of the new generation and all the genetic operations are again performed and the second generation of the same population size is produced. This procedure is repeated till the final goal is achieved. The population size is taken as 80 & GA is run for 100 generation.

4.2. PSO Approach in Brief

Particle swarm optimization (PSO) is a population based stochastic optimization technique developed by Dr. Eberhart and Dr. Kennedy in 1995, inspired by social behavior of bird flocking or fish schooling.

A population is initialized of random feasible solutions and searches for optima by updating generations. In PSO, the potential solutions, called particles have their own positions and velocities move in the search space of an optimization problem by following the current optimum particles. Each particle tracks its own best position found so far in the exploration and each particle searches for better positions in the search space by updating its velocity. The movement of each particle naturally evolves to an optimal or near-optimal solution.

The position of each agent is represented by XY-axis position and the velocity (displacement vector) is expressed by V_x (the velocity along X-axis) and V_y (the velocity along Y-axis). Modification of the agent position is realized by using the position and the velocity information. The behavior of particles in PSO is shown in Fig. 2.

Each agent or particle knows its best value so far (pbest) and its x, y position. Each agent knows the best value so far in the group (gbest) among pbests.

Tab. 1: String representing the control variables in IEEE 14 bus system.

TCSC	SVC			Transformer Tap			Reactive Generations of Generators			
1 Nos.	3 Nos.			3 Nos.			4 Nos.			
1	1	2	3	1	2	3	1	2	3	4

Tab. 2: String representing the control variables in IEEE 30 bus system.

TCSC				SVC				Transformer Tap				Reactive Generations of Generators				
4 Nos.				4 Nos.				4 Nos.				5 Nos.				
1	2	3	4	1	2	3	4	1	2	3	4	1	2	3	4	5

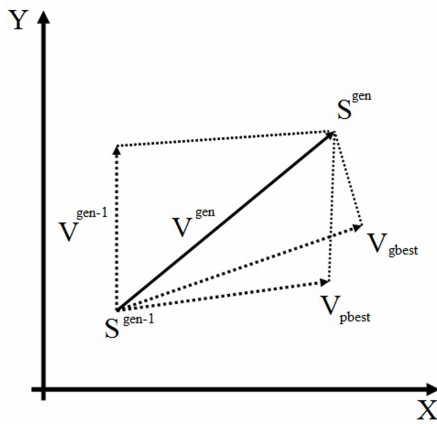

Fig. 2: Behavior of particles in PSO.

Each particle tries to modify their position using the following information:

- the current positions (x, y),
- the current velocities (Vx, Vy),
- the distance between the current position and pbest,
- the distance between the current position and gbest.

The basic equation for the optimization of nonlinear functions using particle swarm optimization technique is:

$$V_i^{gen} = w \cdot V_i^{gen-1} + C_1 \text{rand} (p_{besti} - S_i^{gen-1}) + C_2 \text{rand} (g_{besti} - S_i^{gen-1}), \quad (13)$$

$$S_i^{gen} = S_i^{gen-1} + V_i^{gen}, \quad (14)$$

where w is updated at each iteration:

$$w = w_{max} - \frac{w_{max} - w_{min}}{gen_{max}} gen. \quad (15)$$

Tab. 3: Locations of different FACTS Devices in the Transmission Network.

IEEE 14 bus		IEEE 30 bus	
TCSC in line	SVC in buses	TCSC in line	SVC in line
7	10; 13; 14	25; 41; 28; 5	21; 7; 17; 15

Here $w_{max} = 0.9$; $w_{min} = 0.4$; $gen_{max} = 500$ and $gen =$ current iteration; C_1 and C_2 are set to 2.0.

In PSO, the gbest particle always improves its position and finds the optimum solution and the rest of the population follows it. String representing control variables using PSO are shown in Tab. 1 and Tab. 2.

5. Results and Discussions

After detecting the locations of FACTS devices by power flow analysis it becomes necessary to determine their magnitudes. GA & PSO based optimization technique is run to serve this purpose. IEEE 14 & IEEE 30 bus system is taken as standard test system. Both test systems are loaded (reactive loading is considered) from it's base value to 200 % of it's base value. The locations where different FACTS devices are placed is shown in Tab. 3.

Active power loss without and with FACTS devices using GA & PSO technique is shown in Tab. 4 & Tab. 5 respectively for both systems. The magnitude and phase angle of the voltages of weak nodes without & with FACTS devices for highest reactive loading i.e. for 200 % is shown in Tab. 6 & Tab. 7. Phase angles are given in radian. Here, we see that after connecting FACTS devices, voltage profile of all buses of the IEEE 14 & IEEE 30 bus system improves, though question may arise why we connect FACTS devices if the voltages are in the acceptable range as seen from Tab. 6 & Tab. 7. Our main objective is to reduce overall system

loss with the aid of the FACTS controller. In doing so, the voltage profile improves and transmission loss reduces significantly. A comparative study of the operating cost of the system without and with FACTS devices using GA & PSO is given in Tab. 8 & Tab. 9 for both the systems. From Tab. 8 & Tab. 9, we see that large economic gain is achieved using GA & PSO based placement of FACTS devices in all cases of loading. Here, it is clearly observed from the result, there is a great saving in the system cost in various system loading condition. Table 10 & Tab. 11 shows the amount of FACTS devices in p.u and controlled reactive sources present in the network under different cases of loading using both the techniques and for both the systems. Reactive power flows in different lines before and after the placement of FACTS devices for 200 % loading are shown in Tab. 12 & Tab. 13 for IEEE 14 and IEEE 30 bus system respectively.

It is observed from Tab. 3, that SVC's are connected at the buses 10^{th} , 13^{th} & 14^{th} those are at the finishing ends of lines 13^{th} , 19^{th} & 20^{th} respectively in IEEE 14 bus system, while buses 21^{st} , 7^{th} , 17^{th} & 15^{th} are at the finishing ends of the lines 27^{th} , 26^{th} , 9^{th} & 18^{th} respectively in IEEE 30 bus system, since these are the lines very high reactive power without FACTS devices. After connecting SVC's at these buses, voltage profile at these buses are improved, also reactive power flow is reduced in a large amount in the lines 13^{th} , 19^{th} & 20^{th} in IEEE 14 bus and in the lines 27^{th} , 26^{th} , 9^{th} & 18^{th} in IEEE 30 bus for all cases of loading. The placement of TCSC's in lines using both GA & PSO approaches reduces reactive power flow in lines significantly for both the test systems. As transmission line congestion is directly related with reactive power flows in different lines, we may conclude that line congestion reduces heavily with the reduction of reactive power flow in different lines.

It is also to be noticed that no FACTS device is connected in line 1 because of the fact that it is in between bus 1 and bus 2 though it carries very large active power. Bus 1 is the slack bus and already a FACTS device regulates the voltage of the bus 2. Again in any line or in a bus connected to the line, only one FACTS device can be placed. Tab. 4 & Tab. 5 shows that transmission loss is reduced in a considerable amount with the FACTS devices connected in different locations of the network, as a result operating cost reduces significantly. This effect is observed with different sets of loading values. Hence benefit in terms of saving using both GA & PSO is observed in each cases of loading for both systems as shown in Tab. 8 & Tab. 9. Here, energy cost is taken as 0.06 dollar/kWh.

Figure 3 and Fig. 4 shows the variations of operating cost with generation for 200 % of reactive loading of the system with GA based approach in IEEE 14 & IEEE 30 bus system respectively, while Fig. 5 and

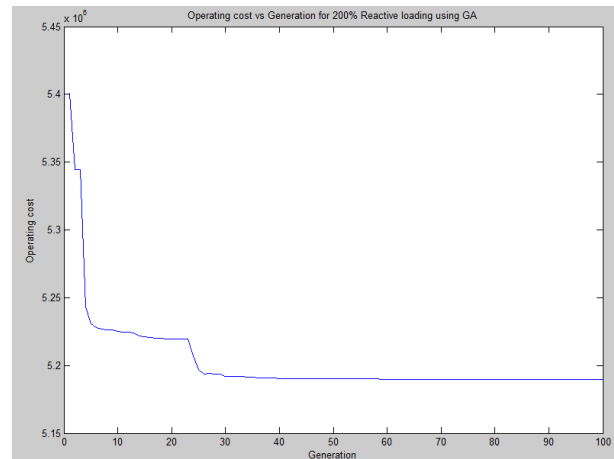

Fig. 3: Variations of operating cost with generation for 200 % of base reactive loading with GA in IEEE 14 bus system.

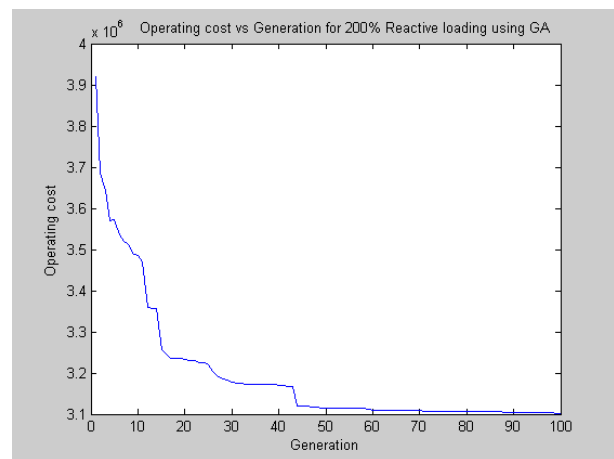

Fig. 4: Variations of operating cost with generation for 200 % of base reactive loading with GA in IEEE 30 bus system.

Fig. 6 shows the variations of operating cost with generation for 200 % of reactive loading of the system with PSO based approach in IEEE 14 & IEEE 30 bus system respectively. Fig. 7 and Fig. 8 shows a single line diagram for IEEE 14 & IEEE 30 bus test system respectively. The results obtained by the GA based method is compared with other standard optimization approach like PSO. It is observed that though PSO yields comparable solution with GA in minimizing transmission loss and transmission cost in the case of IEEE 14 bus system, but in larger test system as in IEEE 30 bus system PSO fails to yield a satisfactory result as GA in all cases of loading.

6. Conclusion

Here Genetic Algorithm (GA) based approach for the placement of FACTS devices and simultaneous control of existing reactive sources is presented. Two different types of FACTS devices are considered. It is

Tab. 4: Active power loss without & with FACTS devices in IEEE 14 bus system.

Reactive Reactive	Active Power Loss without FACTS (p.u.)	Active Power Loss with FACTS using GA (p.u.)	Active Power Loss with FACTS using PSO (p.u.)
100 %	0.1339	0.0666	0.0668
150 %	0.1356	0.0734	0.0734
175 %	0.1368	0.0763	0.0763
200 %	0.1384	0.0983	0.0984

Tab. 5: Active power loss without & with FACTS devices in IEEE 30 bus system.

Reactive Reactive	Active Power Loss without FACTS (p.u.)	Active Power Loss with FACTS using GA (p.u.)	Active Power Loss with FACTS using PSO (p.u.)
100 %	0.0711	0.0406	0.0445
150 %	0.0742	0.0433	0.0478
175 %	0.0765	0.0448	0.0497
200 %	0.0795	0.0573	0.0637

Tab. 6: Bus voltages & phase angles without and with FACTS devices for 200 % reactive loading in IEEE 14 bus system.

Bus. No.	Bus Voltage without FACTS	Bus Angle without FACTS	Evolutionary Methods with FACTS devices	Bus Voltage with FACTS	Bus Angle with FACTS
10	1.0232	-0.2612	GA	1.0454	-0.2633
			PSO	1.0444	-0.2631
13	1.0386	-0.2612	GA	1.0510	-0.2691
			PSO	1.0513	-0.2689
14	1.0066	-0.2764	GA	1.0361	-0.2830
			PSO	1.0334	-0.2818

Tab. 7: Bus voltages & phase angles without and with FACTS devices for 200 % reactive loading in IEEE 30 bus system.

Bus. No.	Bus Voltage without FACTS	Bus Angle without FACTS	Evolutionary Methods with FACTS devices	Bus Voltage with FACTS	Bus Angle with FACTS
7	1.0014	-0.1391	GA	1.0082	-0.1413
			PSO	0.9952	-0.1383
15	1.0036	-0.1797	GA	1.0747	-0.1746
			PSO	1.0574	-0.1711
17	1.0050	-0.1775	GA	1.0797	-0.1733
			PSO	1.0662	-0.1696
21	0.9959	-0.1816	GA	1.0771	-0.1800
			PSO	1.0684	-0.1773

Tab. 8: Operating cost analysis without and with FACTS devices using GA & PSO pproach in IEEE 14 bus system.

Reactive Loading	Operating Cost due to Energy Loss (A) (dollar)	Evolutionary Methods with FACTS devices	Operating Cost (B) $\times 10^6$ (dollar)	Net Saving (A-B) (dollar)
100 %	7037784	GA	3.5046	3533184
		PSO	3.5147	3523084
150 %	7127136	GA	3.9029	3224236
		PSO	3.9135	3213636
175 %	7190208	GA	4.0431	3147108
		PSO	4.0527	3137508
200 %	7274304	GA	5.1896	2084704
		PSO	5.1927	2081604

Tab. 9: Operating cost analysis without and with FACTS devices using GA & PSO pproach in IEEE 30 bus system.

Reactive Loading	Operating Cost due to Energy Loss (A) (dollar)	Evolutionary Methods with FACTS devices	Operating Cost (B) $\times 10^6$ (dollar)	Net Saving (A-B) (dollar)
100 %	3737016	GA	2.1786	1558416
		PSO	2.4052	1331816
150 %	3899952	GA	2.3429	1557052
		PSO	2.6080	1291952
175 %	4020840	GA	2.4745	1546340
		PSO	2.7693	1251640
200 %	4178520	GA	3.1024	1076120
		PSO	3.4460	732520

Tab. 10: Amount of FACTS devices and other reactive sources in the transmission network by GA & PSO in IEEE 30 bus system.

Reactive Loading	SVC amount (p.u.)		TCSC amount in lines (p.u.)		Reactive Generation Qg (p.u.)		Transformer Tap Position (p.u.)	
	GA	PSO	GA	PSO	GA	PSO	GA	PSO
100 %	0.0003	0.0000	0.0001	0.0000	0.2356	0.0000	0.9641	0.9527
	0.0060	0.0000			0.1605	0.2055	0.9516	1.0113
	0.0327	0.0389			0.2370	0.0023	0.9998	0.9087
					0.1812	0.1655		
150 %	0.0000	-0.0572	0.0249	0.0254	0.1829	0.2157	0.9615	0.9695
	0.3245	0.2976			0.2305	0.4271	0.9750	1.0525
	0.0355	0.0515			0.2049	0.1682	0.9977	0.8802
					0.2234	0.0939		
175 %	0.0934	0.1564	0.0025	0.0009	0.1128	0.4559	0.9799	0.9785
	0.0604	0.0434			0.1669	0.3337	0.9433	0.9196
	0.1105	0.1319			0.2189	0.1719	0.9652	1.0363
					0.2133	0.0384		
200 %	0.0351	0.0273	0.0011	0.0000	0.2230	0.5208	0.9896	0.9774
	0.0663	0.0770			0.2282	0.3454	0.9567	1.0132
	0.0643	0.0492			0.2212	0.2380	0.9378	0.8748
					0.2141	0.1696		

Tab. 11: Amount of FACTS devices and other reactive sources in the transmission network by GA & PSO in IEEE 14 bus system.

Reactive Loading	SVC amount (p.u.)		TCSC amount in lines (p.u.)		Reactive Generation Qg (p.u.)		Transformer Tap Position (p.u.)	
	GA	PSO	GA	PSO	GA	PSO	GA	PSO
100 %	0.0892	0.0000	0.0001	0.1463	0.3409	0.6000	0.9099	0.9000
	0.0511	0.0000	0.0419	0.0419	0.1815	0.0000	0.9859	0.9000
	0.0398	0.0000	0.0002	0.1049	0.1911	0.0000	0.9133	0.9248
	0.0621	0.0000	0.0515	0.1388	0.1975	0.4000	0.9344	0.9000
150 %	0.1586	0.0869	0.0010	0.1463	0.3899	0.6000	0.9431	0.9000
	0.1172	0.0000	0.0117	0.0419	0.1818	0.0000	1.0109	0.9000
	0.0714	0.0000	0.0002	0.1049	0.3185	0.0000	0.9331	0.9358
	0.1036	0.1510	0.0545	0.1388	0.2371	0.2474	0.9081	0.9000
175 %	0.3351	0.3202	0.0008	0.1463	0.3630	0.0672	0.9601	0.9195
	0.2194	0.0063	0.0419	0.0419	0.2073	0.0183	0.9004	0.9308
	0.1877	0.2336	0.0008	0.1049	0.2158	0.4656	0.9993	0.9673
	0.1350	0.2018	0.0501	0.1388	0.1606	0.2370	0.9482	0.9006
200 %	0.2399	0.1457	0.0011	0.1463	0.3318	0.6000	0.9366	0.9000
	0.1673	0.0000	0.0051	0.0419	0.2240	0.0000	0.9880	0.9000
	0.1149	0.0000	0.0004	0.1049	0.2751	0.0000	0.9189	0.9483
	0.1579	0.1089	0.0500	0.1388	0.2145	0.3168	0.9001	0.9000
				0.1357	0.0000			

Tab. 12: Comparative study of rective power flow in lines using GA & PSO based proposed approach for 200 % of base loading in IEEE 14 bus.

Lines	For reactive loading of 200 % (before) (p.u.)	For base reactive loading of 200 % using GA (p.u.)	For base reactive loading of 200 % using PSO (p.u.)
7	0.1417	0.0139	0.0503
13	0.0414	0.0538	0.0604
19	0.0222	-0.0013	-0.0020
20	0.0638	0.0194	0.0277

Tab. 13: Comparative study of rective power flow in lines using GA & PSO based proposed approach for 200 % of base loading in IEEE 30 bus.

Lines	For reactive loading of 200 % (before) (p.u.)	For base reactive loading of 200 % using GA (p.u.)	For base reactive loading of 200 % using PSO (p.u.)
5	0.0384	0.0388	0.0380
25	0.0664	0.0649	0.0879
28	0.0883	0.0115	0.0495
41	0.0751	0.0662	0.0388
9	0.1032	0.0100	0.0714
18	0.1365	-0.0227	-0.0034
26	0.0860	0.0173	0.1544
27	0.1925	0.0070	0.0923

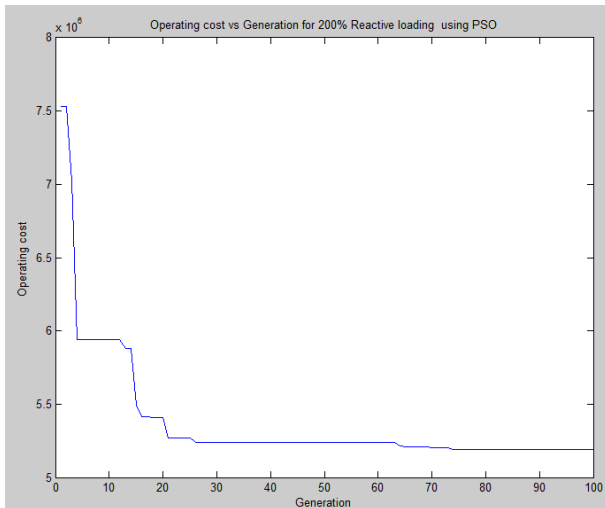

Fig. 5: Variations of operating cost with generation for 200 % of base reactive loading with PSO in IEEE 14 bus system.

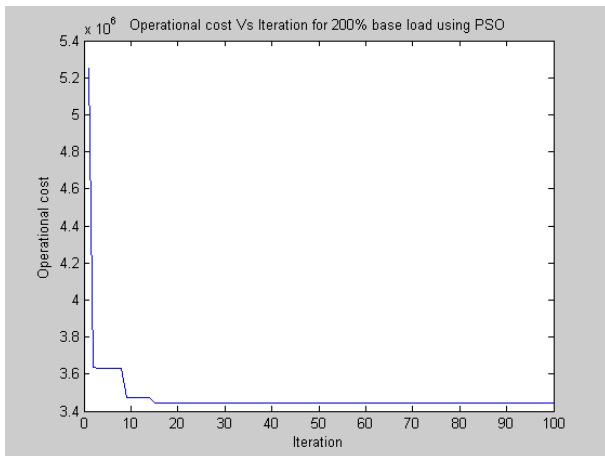

Fig. 6: Variations of operating cost with generation for 200 % of base reactive loading with PSO in IEEE 30 bus system.

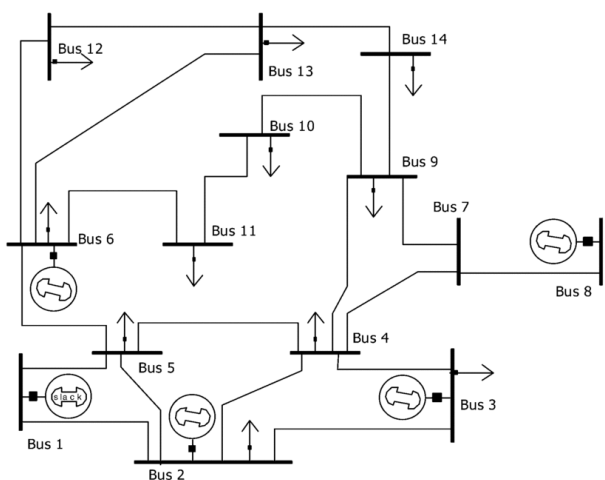

Fig. 7: Single line diagram of IEEE 14 bus system.

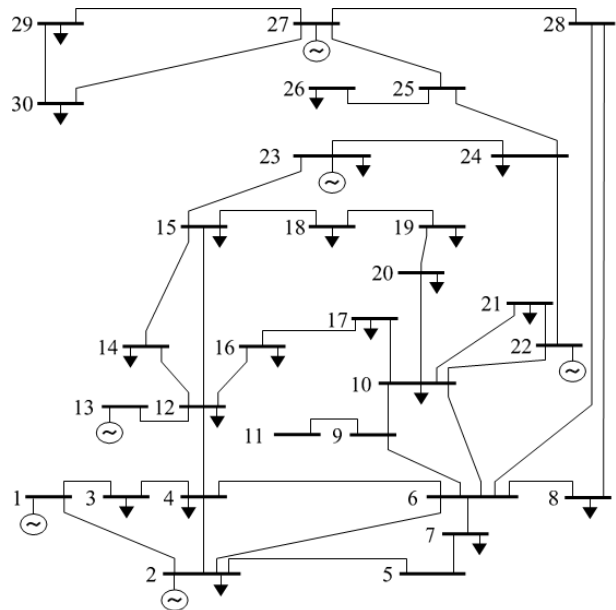

Fig. 8: Single line diagram of IEEE 30 bus system.

clearly evident from the results that effective placement of FACTS devices in proper locations along with the proper planning of existing reactive sources by using suitable optimization technique can significantly improve system performance. Also it is significantly noticeable from the results that the FACTS devices can be an alternative to reduce the flows in heavily loaded lines, resulting in an increased loadability, low system loss, improved stability of the network. Particle Swarm Optimization (PSO) based algorithm is developed for the purpose of comparison with the GA based approach. But GA based approach is more effective in minimizing the total operating cost, transmission loss than PSO based approach. Hence this GA based approach could be a new technique for planning of the existing reactive sources and efficient utilization of FACTS devices for improved power transfer.

References

- [1] HINGORANI, N. G. High Power Electronics and flexible AC Transmission System. *Power Engineering Review*. 1988, vol. 8, iss. 7, pp. 3-4. ISSN 0272-1724. DOI: 10.1109/MPER.1988.590799.
- [2] IBRAHIM, E. Optimal Allocations of SVCs for Improvement of Power System Performance. *Electric Power Components and Systems*. 2003, vol. 31, iss. 1, pp. 27-46. ISSN 1532-5008. DOI: 10.1080/15325000390112044.
- [3] ABDELAZIZ, A. Y., M. A. EL-SHARKAWY and M. A. ATTIA. Optimal Location of Thyristor-

- controlled Series Compensators in Power Systems for Increasing Loadability by Genetic Algorithm. *Electric Power Components and Systems*. 2011, vol. 39, iss. 13, pp. 1373–1387. ISSN 1532-5008. DOI: 10.1080/15325008.2011.584108.
- [4] PREEDAVICHIT, P. and S. C. SRIVASTAVA. Optimal reactive power dispatch considering FACTS devices. *Electric Power Systems Research*. 1998, vol. 46, iss. 3, pp. 251–257. ISSN 0378-7796. DOI: 10.1016/S0378-7796(98)00075-3.
- [5] BHATTACHARYYA, B., S. K. GOSWAMI and R. C. BANSAL. Loss Sensitivity Approach in Evolutionary Algorithms for Reactive Power Planning. *Electric Power Components and Systems*. 2009, vol. 37, iss. 3, pp. 287–299. ISSN 0378-7796. DOI: 10.1080/1532500802454468.
- [6] CHUNG, T. S. and Y. Z. LI. A hybrid GA approach for OPF with consideration of FACTS devices. *Power Engineering Review*. 2000, vol. 20, iss. 8, pp. 54–57. ISSN 0272-1724. DOI: 10.1109/39.857456.
- [7] OSMAN, M. S., M. A. ABO-SINNA and A. A. MOUSA. A solution to the optimal power flow using genetic algorithm. *Applied Mathematics and Computation*. 2004, vol. 155, iss. 2, pp. 391–405. ISSN 0096-3003. DOI: 10.1016/S0096-3003(03)00785-9.
- [8] GERBEX, S., R. CHERKAoui a A. J. GERMOND. Optimal location of multi-type FACTS devices in a power system by means of genetic algorithms. *Transactions on Power Systems*. 2001, vol. 16, iss. 3, pp. 537–544. ISSN 0885-8950. DOI: 10.1109/59.932292.
- [9] RASHED, G. I. and Y. SUN. Optimal Placement of Thyristor Controlled Series Compensation for Enhancing Power System Security Based on Computational Intelligence Techniques. *Procedia Engineering*. 2011, vol. 15, pp. 908–914. ISSN 1877-7058. DOI: 10.1016/j.proeng.2011.08.168.
- [10] NAGALAKSHMI, S. and N. KAMARAJ. Comparison of computational intelligence algorithms for loadability enhancement of restructured power system with FACTS devices. *Swarm and Evolutionary Computation*. 2012, vol. 5, pp. 17–27. ISSN 2210-6502. DOI: 10.1016/j.swevo.2012.02.002.
- [11] IWARI, P. K. and Y. R. SOOD. Optimal location of FACTS devices in power system using Genetic Algorithm. In *World Congress on Nature & Biologically Inspired Computing*. Coimbatore: IEEE, 2009, pp. 1034–1040. ISBN 978-1-4244-5053-4. DOI: 10.1109/NABIC.2009.5393860.
- [12] DAS, D. Reactive power compensation for radial distribution networks using genetic algorithm. *International Journal of Electrical Power*. 2002, vol. 24, iss. 7, pp. 573–581. ISSN 0142-0615. DOI: 10.1016/S0142-0615(01)00068-0.
- [13] LIE, T. T. and W. DENG. Optimal flexible AC transmission systems (FACTS) devices allocation. *International Journal of Electrical Power*. 1997, vol. 19, iss. 2, pp. 125–134. ISSN 0142-0615. DOI: 10.1016/S0142-0615(96)00036-1.
- [14] VITORINO, R. M., H. M. JORGE and L. P. NEVES. Loss and reliability optimization for power distribution system operation. *Electric Power Systems Research*. 2013, vol. 96, pp. 177–184. ISSN 0378-7796. DOI: 10.1016/j.epr.2012.11.002.
- [15] GHAREMANI, Esmaeil a Innocent KAMWA. Optimal placement of multiple-type FACTS devices to maximize power system loadability using a generic graphical user interface. *Transactions on Power Systems*. 2013, vol. 28, iss. 2, pp. 764–778. ISSN 0885-8950. DOI: 10.1109/TPWRS.2012.2210253.
- [16] RASHED, G. I., Y. SUN a H. I. SHAHEEN. Optimal Location and Parameter Setting of TCSC for Loss Minimization Based on Differential Evolution and Genetic Algorithm. *Physics Procedia*. 2012, vol. 33, pp. 1864–1878. ISSN 1875-3892. DOI: 10.1016/j.phpro.2012.05.296.
- [17] ABUL'WAFa, A. R. Optimal capacitor allocation in radial distribution systems for loss reduction: A two stage method. *Electric Power Systems Research*. 2013, vol. 95, pp. 168–174. ISSN 0378-7796. DOI: 10.1016/j.epr.2012.09.004.
- [18] CAI, L. J., I. ERLICH and G. STAMTSIS. Optimal choice and allocation of FACTS devices in deregulated electricity market using genetic algorithms. In: *Power Systems Conference and Exposition*. New York: IEEE, 2004, pp. 815–821. ISBN 0-7803-8718-X. DOI: 10.1109/PSCE.2004.1397562.
- [19] GOLDBERG, D. E. *Genetic algorithms in search, optimization, and machine learning*. Boston: Addison-Wesley, 1989. ISBN 02-011-5767-5.

About Authors

Biplab BHATTACHARYYA born in 9th January, 1970. He is currently working as Associate Professor of Electrical Engineering in the Indian School of Mines University, Dhanbad, India. He has joined in

the Electrical Engineering department as Assistant Professor in the year of 2007. Then he promoted to the post of Associate Professor on 2010. He had served department of Electrical Engineering of National Institute of Technology, Durgapur, India for six years as senior Lecturer. He was in the position of Lecturer in the Electrical Engineering department of BITS, Pilani, Rajasthan, India for nearly one year. He worked as Assistant Engineer (Electrical Test), in a reputed cable industry for nearly three years. He obtained B.Sc (Hons) in Physics from Calcutta University, India in 1990. He obtained his B-Tech and M-Tech degree in the field of Electrical machines and Power system from Calcutta University in 1993 and 1995 respectively. He obtained his Phd degree in Engineering from the department of Electrical Engineering, Jadavpur University, India in 2006. He has published several technical papers in international/national journals and conference proceedings. His research area mainly

includes Evolutionary approaches, Power system optimization, Planning, Dispatch, FACTS devices.

Vikash Kumar GUPTA born in 9th January 1984. He received B. E. degree Anna University, Chennai in 2009, and the M.Tech degree from B.I.T. Sindri, Dhanbad, Jharkhand in 2011. Currently, he is the Research Scholar in the Electrical Engineering Department, Indian School of Mines, Dhanbad, Jharkhand. His area of interest is Power System.

Sanjay KUMAR born in 5th June 1980. He received B.Tech degree from N.I.T Jamshedpur in 2006, M.Tech from N.I.T Patna in 2010. He has having two years of teaching experience and currently, he is the Research Scholar in the Electrical Engineering Department, Indian School of Mines, Dhanbad, Jharkhand.