

# PERIMETER SYSTEM BASED ON A COMBINATION OF A MACH-ZEHNDER INTERFEROMETER AND THE BRAGG GRATINGS

Marcel FAJKUS, Jan NEDOMA, Petr SISKA, Lukas BEDNAREK,  
Stanislav ZABKA, Vladimir VASINEK

Department of Telecommunications, Faculty of Electrical Engineering and Computer Science,  
VSB–Technical University of Ostrava, 17. listopadu 15/2172, 708 33 Ostrava-Poruba, Czech Republic

marcel.fajkus@vsb.cz, jan.nedoma@vsb.cz, petr.siska@vsb.cz, lukas.bednarek@vsb.cz,  
stanislav.zabka@centrum.sk, vladimir.vasinek@vsb.cz

DOI: 10.15598/aeec.v14i3.1752

**Abstract.** *Fiber optic interferometers and Bragg gratings belong to the group of very precise and sensitive devices that allow measuring very small deformation, temperature or vibration changes. The described methodology presents the use of a Mach-Zehnder interferometer and Bragg gratings together as a sensor system for detecting and monitoring movement within the defined perimeter of  $2.5 \times 1$  m. Analyses of the dynamic changes in interferometric patterns were a basis for this method. Also the signal maximum amplitude was measured and compared with the noise background. Perimeter disruptions can be detected by Bragg gratings due to its large deformation sensitivity in transversal or perpendicular directions. The result is then evaluated in the spectral domain. In terms of detected persons it showed very good results. The combination of these sensors was chosen for monitoring both the static and dynamic phenomena. Author's aim is to take advantage of both devices positive properties. Thus, the system has the ability to identify people due to frequency analysis in case of interferometers as well as dynamic weighting thanks to Bragg gratings.*

## Keywords

*Bragg gratings, Mach-Zehnder interferometer, monitoring of movement, perimeter system.*

## 1. Introduction

Security and safety systems are a set of technical and organizational measures. These measures stand be-

tween a protected interest and the danger. It may be a property or other values that we protect against theft, damage, destruction or disruption by any other way. As for standard electrical systems, the installation of detection elements is limited to certain parts of the object, due to a reduction of the financial costs. These parts are mostly entrances into objects or rooms with valuable things, or into places with dangerous material etc. In addition, the detection elements must be either hidden or resistant to mechanical deactivation by the intruder or through electromagnetic jammers. All disadvantages of standard systems can be eliminated by using the security system based on fiber-optic principles. Optical fiber can be used either for detection of the intrusion or for transmission of information about the state of the monitored object. Optical fibers can be installed easily into floors, windows or walls. These fibers can be installed so as to be invisible, undetectable or untraceable due to the very small dimensions. Moreover, these elements cannot be decommissioned by the use of jammers due to the immunity against electromagnetic interference. The price of an optical fiber is low, therefore fiber-optic security systems can be implemented in each object and building.

## 2. Operating Principles

Perimeter detection systems based on the FBG generally consist of a network of FBGs. The network has ten or more FBGs within a single detection system. Thus created networks are capable of detecting disruptions of static and dynamic processes. Disruption of the object causes the formation of the vertical force.

The vertical force will act on one or more FBG sensors, depending on the density of the sensor network. The disadvantage of such systems is the necessity to use more FBGs. Other disadvantages are decreasing of the effectiveness of the detection system and more complex evaluation part in case of large detection surface. Examples of embodiments show articles [1], [2], [3] and [4].

Perimeter detection systems based only on the use of interferometric measurements utilize the known types of interferometric sensors. These systems use the combination of two or more interferometers which form a closed circuit. The resolving capability of such systems is both dependent on the size of the detection area and requires a highly coherent laser source and a more complex evaluation part for the processing and synchronization. Amplitude response can be monitored in dependence on time to evaluate the signal. We can detect the distortion using the frequency analysis in the case of using an FFT transform. A disadvantage arises in detecting static processes when these sensors based on the operating principle of interferometric measurements are ineffective. Examples of embodiments show articles [5] and [6].

Perimeter systems were realized mainly through the use of one type of sensors where we encounter disadvantages that are mentioned above. The combination of FBG gratings and fiber-optic interferometers was chosen with regard to the possibility of monitoring of static and dynamic processes simultaneously. Bragg gratings (hereinafter "FBG") are a typical example of a fiber-optic sensor for use in security systems. FBG are formed by the periodic structure changes of the refractive index within of the core of the optical fiber (Fig. 1). There is a partial spectral reflection of the transmitted light on these interfaces. If we bring wide-spectrum light into an optical fiber with FBG, then a certain part of the spectrum is reflected, and other wavelengths are transmitted through Bragg grating without loss.

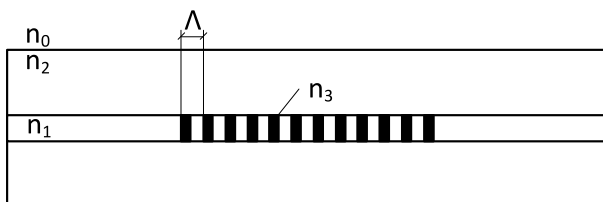

Fig. 1: Structure of the FBG.

The reflected wavelength is called the Bragg wavelength and it is given by:

$$\lambda_B = 2n_{eff}\Lambda, \quad (1)$$

where  $n_{eff}$  is the effective refractive index, and  $\Lambda$  is the period of changes of the refractive index in the

optical fiber. A Bragg grating utilizes the temperature and deformation sensitivity of said parameters on the surrounding impulses in sensorial applications. Respective evaluation is performed in the spectral domain. The temperature sensitivity is  $10.1 \text{ pm}\cdot\text{C}^{-1}$  for the FBG with Bragg wavelength of 1550 nm, and tensile deformation is  $1.01 \text{ pm}\cdot\mu\text{strain}^{-1}$  for same Bragg wavelength. FBG sensors belong to the group of single-point sensors, but they can be very easily connected to achieve the multipoint measurement using multiplexing techniques. The wavelength division multiplex is the simplest technique which uses the spectral separation of the signal from the individual FBG sensors. Time division multiplex can be used instead of wavelength division multiplex. Time division multiplexing offers up to several hundred sensors per one optical fiber, but the implementation of the evaluation is significantly more complex [7].

The use of fiber optic interferometers is the other very suitable possibility for solving problems. These devices enable measurement with high sensitivity over a long distance. The reason is obvious -the light passes through the fiber with low attenuation in comparison with electrical cables, having metallic conductivity. Other advantages of fiber optic interferometers are a large dynamic range, their resistance to electrostatic and electromagnetic interference, and the fact that they are relatively less affected by aging components from which they are composed. Sensing of the physical or chemical values is manifested by phase change of the received light beam. This type of sensor requires a single mode optical fiber and a coherent radiation source. It offers the possibility to achieve maximum sensitivity within the fiber-optic sensors. Typical sensitivity can be achieved in the order of  $10^{-8}$  (the wavelength of light is about  $1 \mu\text{m}$  in the optical fiber). The design of the reference arm of the interferometer is the basis for fiber interferometry. The arrangement must be designed to a maximum of the elimination of unwanted signals. Noise (background signal) has the origin in the thermal phenomena, mechanical changes, or changes in the refractive index of the material. It is also necessary to consider different non-specific reactions that we do not want to detect (physical and chemical reactions). It is desirable that the reference arm is positioned as close as possible to the measuring arm. The reference and measuring arms should have the same length, structure and other properties. The only difference must be sensitivity to a specific value, which we want to detect [8] and [9].

Interferometry is an optical method that monitors the phase difference between two optical beams which pass through similar (if possible identical) optical paths. A phase shift arises in the interferometer. Interferometry is able to detect three parameters. These

parameters affect the optical beam propagating along the optical path:

- change of the propagation speed,
- change of the wavelength,
- change of the route length.

If the change occurs in any of these parameters, then a change also occurs in a wave-phase. This change depends on the length of the path  $L$ , the refractive index  $n$ , and the wavelength  $\lambda$  according to the equation:

$$\Phi = 2\pi L \frac{n}{\lambda} = kLn, \quad (2)$$

where  $L$  is the length of used fiber,  $n$  is the refractive index of the core,  $\lambda$  is the wavelength of the radiation source and  $k$  is the size of the wave vector. Fluctuations of phase delay of the interferometer can be described as:

$$\frac{d\phi}{\phi} = \frac{dL}{L} + \frac{dn}{n} + \frac{dk}{k}. \quad (3)$$

Variable  $V$  (contrast, visibility) is introduced to evaluate the degree of interference provided by the interferometer:

$$V = \frac{I_{max} - I_{min}}{I_{max} + I_{min}}. \quad (4)$$

Visibility depends on the relative intensity of the signal and reference beams, their relative states of polarization and mutual coherence.

$I_{max}$  is the maximum observed intensity for linearly polarized waves in the same direction:

$$I_{max} = I_1 + I_2 + 2A_1A_2, \quad (5)$$

and  $I_{min}$  is the minimum observed intensity:

$$I_{min} = I_1 + I_2 - 2A_1A_2, \quad (6)$$

where  $I_1, I_2$  indicate the intensity of interference waves,  $A_1, A_2$  indicate the maximum amplitudes of the waves:

$$I_1 = I_0 [1 - V \cos(\phi_r - \phi_s)], \quad (7)$$

$$I_2 = I_0 [1 + V \cos(\phi_r - \phi_s)], \quad (8)$$

where  $I_0$  is the mean signal value,  $\phi_r$  is the phase of the reference beam, and  $\phi_s$  is the phase of the signal beam.

The output intensity of the interferometer can be expressed as:

$$I = \frac{I_0 \cdot \alpha}{2} (1 + \cos \Lambda\phi), \quad (9)$$

where  $\alpha$  indicates the optical losses of the interferometer, and  $\Lambda\phi$  is difference between phases in both arms and is given by  $\Lambda\phi = \phi_r - \phi_s$ . The output intensity is converted into electric current using the photodetector. Differential combination of those currents produces the output:

$$i = \varepsilon \cdot l_0 \cdot \alpha \cdot \cos(\phi_d + \phi_s \sin \omega t), \quad (10)$$

where  $\varepsilon$  is the sensitivity of the photodetector,  $\phi_d$  is changing the phase shift,  $\phi_s$  is the phase modulation amplitude, and  $\omega$  is frequency. The output current from the interferometer is derived from two-phase shifts. The first  $\phi_d$  member (slow changes over time) is the mean value of the variation in the intensity of random influences. The second member ( $\phi_s \cdot \sin \omega t$ ) is a phase change caused by an external source of vibrations with the frequency omega [10] and [11].

Optical fibers containing FBG can be installed, in the security technology for example, into the floor in combination with fiber-optic interferometers. The sensory network with FBG sensors must be installed to cover large objects or surfaces. Disruption of the object causes the formation of vertical force. This force will act on one or more FBG sensors, depending on the density of the sensory network. This information is detectable in the evaluation unit. Implementation of only one sensor can be used for fiber optic interferometers due to the very high sensitivity. The combination of two or more interferometric sensors can be used to cover a larger surface of an object. The amplitude response of the signal can be monitored for evaluation in dependence on time. In the case of FFT transform, detecting the intrusion can be monitored by the implementation of frequency analysis. The combination of FBG and optical interferometers was chosen with regard to the possibility of monitoring both the static and dynamic processes.

### 3. Experimental Setup

Practical measurements were divided into the following four phases.

- Testing to achieve maximum possible signal to noise ratio (SNR).
- Achieving a situation where the implemented sensor does not detect impulses outside the test perimeter of  $2.5 \times 1$  m.
- Testing the detection system with the interferometric sensor and with FBG.
- Testing the combination of both sensors.

The test area was chosen to maximize the ability of detection of static and dynamic processes in the  $2.5 \times 1$  m range.

Mach-Zehnder interferometer is the solution basis of the interferometric sensor operating with the optical fiber with standard specification G.652D. The interferometer is implemented with respect to the greatest possible sensitivity to the low frequency. Results of the frequency analysis showed that vibration caused by the test persons are low frequencies. The tunable laser source was used as the excitation source operating at the wavelength of 1550 nm. The output power was set to their reference value of 1 mW. This value was constant for all experimental measurements. Isolator was inserted for filtering unwanted back reflections to the source of radiation. A part of the signal processing (electronic evaluation part) includes the PbSe photodetector which detects the signal resulting from the interference of optical beams from the reference (L2) and measuring (L1) interferometer arms. The output intensity is converted into a measurable electric current. The high pass filter is used to ensure the zero offset voltage, amplifier and analog-digital converter (NI USB 6210) as well. The actual evaluation software works for the interferometric sensor with the signal in the time domain. The application displays the progress of the sensed signal as voltage in dependence on time (amplitude spectrum of the input signal). The block scheme of the measurement is shown in Fig. 2.

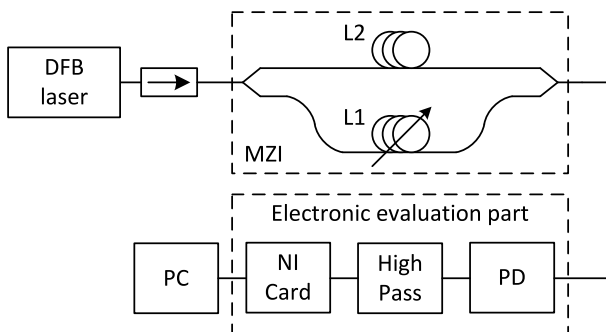

**Fig. 2:** A scheme of the measurement with the interferometric sensor.

The total of 250 repeated walkthroughs of 10 test persons were performed around the detection pad of  $2.5 \times 1$  m for testing in order to obtain the maximum possible signal regarding noise ratio (SNR). Typical values of amplitude response did not exceed 0.02 V at the distances of 1, 2 and 3 m (Fig. 3). SNR level 0.1 V was determined on the basis of the obtained values. Application assessed the response as sufficient to confirm the passage of the subject from this value

The total of 100 repeated walkthroughs of 10 test persons were performed through the perimeter system (the responses caused by passing through the detection pad of  $2.5 \times 1$  m) to test the detection system with an in-

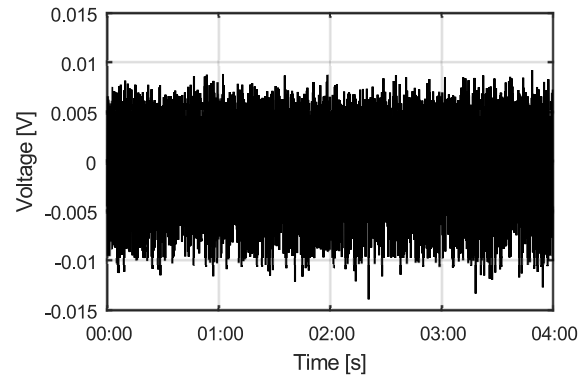

**Fig. 3:** A typical record of the passage of a person outside the detection pad-detection by interferometric sensor.

terferometric sensor. Each test subject performed four steps, and the response was subsequently evaluated. Individual persons were detected with 100% efficiency. The typical results are shown below (Fig. 4) for two test persons in the time domain. Typical values of the amplitude response varied from 0.5 to 2 V according to the test persons with weight, age as well as gender differences.

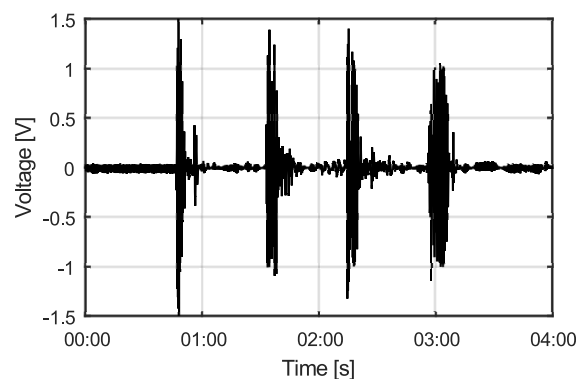
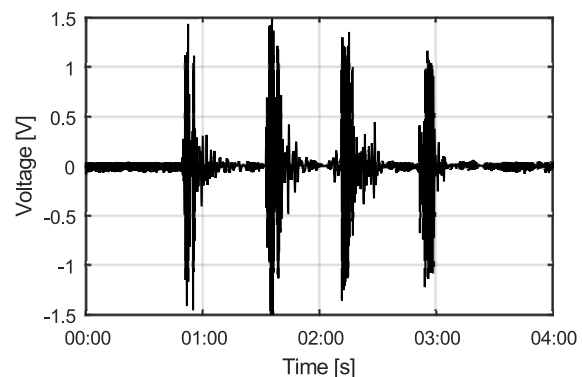

**Fig. 4:** A typical record of the walkthroughs of two different test persons over the detection pad-detection by the interferometric sensor.

A tunable laser was used for experimental verification of the perimeter system with FBG sensor (Fig. 5). Output radiation was spectral swept in the range from

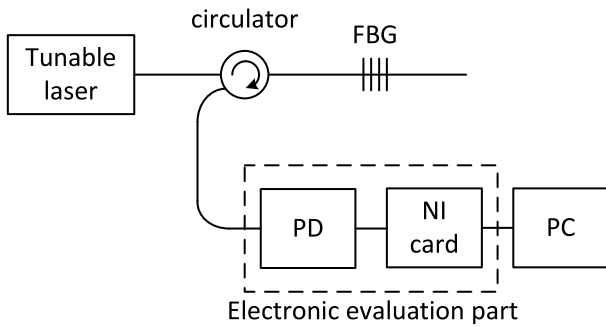

Fig. 5: A scheme of the measurement with the FBG sensor.

1548 to 1557 nm with the period of 250 ms. FBG sensor was tuned to the Bragg wavelength of 1550.104 nm. The reflected light was both detected by a photodetector in time periods and digitized by the measuring card NI USB 6210. The application was implemented on the PC in LabView that shows the resulting spectral characteristic.

The total of 100 repeated walkthroughs of 10 test persons were performed through the perimeter system (the responses caused by passing through the detection pad of 2.5×1 m) to test the detection system with the FBG sensor. Individual persons were detected with 100% efficiency. Each test person performed three steps within one repetition, the response was subsequently evaluated (Fig. 6). The progress of the repeated walkthroughs of the test persons was tested at the end of the measurement after walkthrough over the detection pad versus stopping and staying on the spot (Fig. 7).

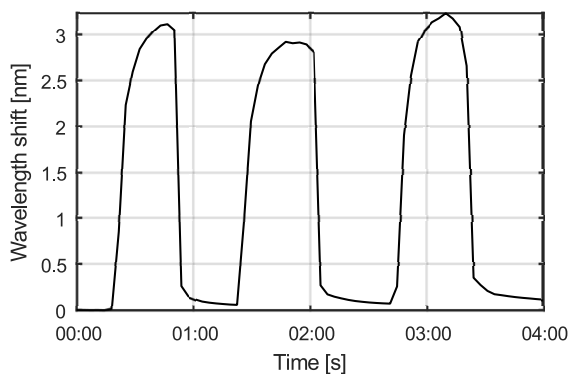

Fig. 6: A typical record of the walkthrough of a test person over the detection pad detected by the FBG sensor.

The testing scheme with the combination of both sensors is shown in Fig. 8. The combination of these sensors is able to monitor both static and dynamic phenomena simultaneously. This combination reduces the risk of failure of the perimeter system of dimensions 2.5×1 m to a minimum. The graph describes a dynamic phenomenon monitored by an interferometric

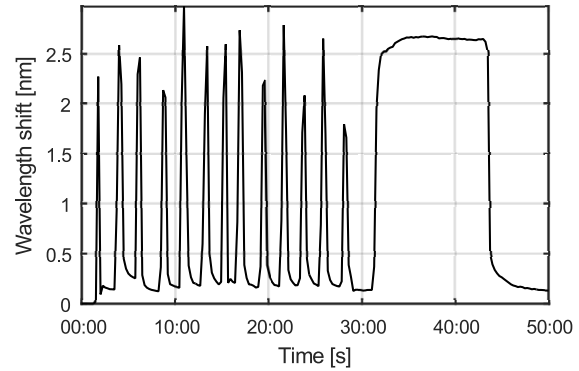

Fig. 7: A typical record of the repeated walkthroughs of a test person over the detection pad (00:00–30:00) versus stopping and staying on the spot (30:00–45:00) detected by the FBG sensor.

sensor. Three steps and stopping are monitored with the FBG sensor (Fig. 9).

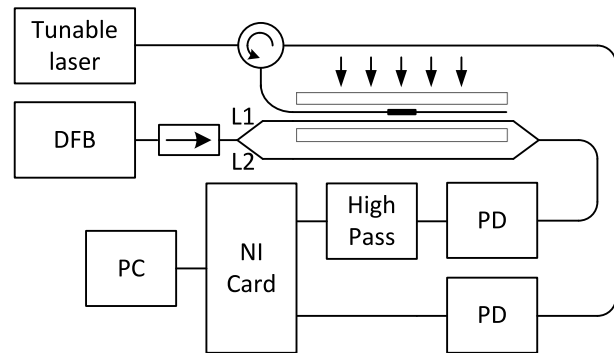
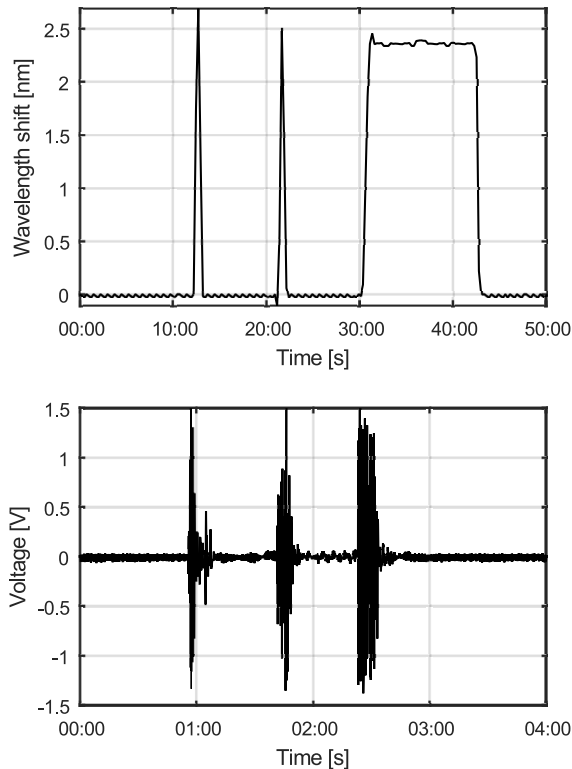

Fig. 8: A scheme of the measurement with the FBG sensor and the Mach-Zehnder interferometer sensor.

## 4. Conclusion

The reported results showed that the combination of the fiber optic interferometer and Bragg grating may find its application in safety and security systems. The methodology of the sensors was chosen with a view to the use of the advantageous properties of both types of sensors (detection of the static as well as dynamic phenomena). The test was focused on the maximizing ability of detect testing persons within a detection pad with the dimensions of 2.5×1 m. The results showed that the individual objects were detected with 100% efficiency in cases using both an interferometric sensor and the sensor with FBG. For both sensors, there was a total of 200 repetitions performed (10 different test persons). Each testing person performed steps within one measurement. Tests showed the combination of these sensors is able to monitor both static and dynamic phenomena simultaneously, and eliminates the risk of failure of our perimeter system. A further re-



**Fig. 9:** An example of record of the walkthrough of test persons over the detection pad—the combination of the interferometric sensor (bottom) and the FBG sensor (top).

search will focus on expanding the proposed prototype. The interferometric sensor detects the intrusion of the monitored perimeter using frequency analysis, and the FBG sensor expands with the possibility of dynamic weighing of the persons.

## Acknowledgment

This article was supported by the projects of the Technology Agency of the Czech Republic TA03020439 and TA04021263, and by Ministry of Education of the Czech Republic within the project no. SP2016/149. The research has been partially supported by the Ministry of Education, Youth and Sports of the Czech Republic through the grant project no. CZ.1.07/2.3.00/20.0217 within the frame of the operation programme Education for competitiveness financed by the European Structural Funds and from the state budget of the Czech Republic. This article was supported too by the project VI20152020008 (GUARDSENSE II).

## References

- [1] WU, H., Y. QIAN, W. ZHANG, H. LI and X. XIE. Intelligent detection and identification in fiber-optical perimeter intrusion monitoring system based on the FBG sensor network. *Photonic Sensors*. 2015, vol. 5, iss. 4, pp. 365–375. ISSN 1674-9251. DOI: 10.1007/s13320-015-0274-8.
- [2] ALLWOOD, G., S. HINCKLEY and G. WILD. Optical Fiber Bragg grating based intrusion detection systems for homeland security. In: *IEEE Sensors Applications Symposium*. Galveston: IEEE, 2013, pp. 66–70. ISBN 978-1-4673-4636-8. DOI: 10.1109/SAS.2013.6493558.
- [3] LI, S., J. MA and J. HU. Rockfall hazard alarm strategy based on FBG smart passive net structure. *Photonic Sensors*. 2015, vol. 5, iss. 1, pp. 19–23. ISSN 1674-9251. DOI: 10.1007/s13320-014-0203-2.
- [4] CATALANO, A., F. A. BRUNO, M. PISCO, A. CUTOLO and A. CUSANO. An intrusion detection system for the protection of railway assets using fiber bragg grating sensors. *Sensors*. 2014, vol. 14, iss. 10, pp. 18268–18285. ISSN 1424-8220. DOI: 10.3390/s141018268.
- [5] JIANG, J., Y. JIANG, D. LIU, S. WANG and X. LI. Fiber-optic perimeter security system based on dual Mach-Zehnder interferometer structure. *Guangxue Jishu/Optical Technique*. 2015, vol. 41, iss. 3, pp. 193–196. ISSN 1002-1582.
- [6] ALI, T. H., H. MEDJADBA, L. M. SIMOHAMED and R. CHEMALI. Intrusion detection and classification using optical fiber vibration sensor. In: *3rd International Conference on Control, Engineering and Information Technology*. Tlemcen: IEEE, 2015, pp. 1–6. ISBN 978-1-4799-8212-7. DOI: 10.1109/CEIT.2015.7233060.
- [7] KERSEY, A. D., M. A. DAVIS, H. J. PATRICK and M. LEBLANC. Fiber grating sensors. *Journal of Light wave Technology*. 1997, vol. 15, iss. 8, pp. 1442–1463. ISSN 0733-8724. DOI: 10.1109/50.618377.
- [8] LOPEZ-HIGUERA, J. M. *Handbook of Optical Fibre Sensing Technology*. 1st ed. Dublin: Wiley, 2002. ISBN 978-0-471-82053-6.
- [9] GOODWIN, E. P. and J. C. WYANT. *Field guide to interferometric optical testing*. 1st ed. Bellingham: SPIE, 2006. ISBN 978-0819465108.
- [10] UDD, E. and W. B. SPILLMAN. *Fiber optic sensors: an introduction for engineers and scientists*.

2nd ed. Hoboken: Wiley, 2011. ISBN 978-0-470-12684-4.

- [11] SALEH, B. E. and M. C. TEICH. *Zaklady fotoniky*. 1st ed. Praha: Matfyzpress, 1995. ISBN 80-85863-05-7.

## About Authors

**Marcel FAJKUS** was born in 1987 in Ostrava. In 2009 he received a Bachelor's degree from VSB–Technical University of Ostrava, Faculty of Electrical Engineering and Computer Science, Department of Telecommunications. Two years later, he received a Master's degree in the field of Telecommunications in the same workplace. He is currently a Ph.D. student, and he works in the field of optical communications and fiber optic sensor systems.

**Jan NEDOMA** was born in 1988 in Prostejov. In 2012 he received a Bachelor's degree from VSB–Technical University of Ostrava, Faculty of Electrical Engineering and Computer Science, Department of Telecommunications. Two years later, he received his Master's degree in the field of Telecommunications in the same workplace. He is currently a Ph.D. student, and he works in the field of optical communications and fiber optic sensor systems.

**Petr SISKÁ** was born in 1979 in Kromeriz. In 2005 he finished M.Sc. study at VSB–Technical University of Ostrava, Faculty of Electrical Engineering and Computer Science, Dept. of Electronic and Telecommunications. Three years later, he finished Ph.D. study in Telecommunication technologies. Currently he is an employee of the Department of Telecommunications. He is interested in Optical communications, Fiber optic sensors and Distributed Temperature Sensing systems.

**Lukas BEDNAREK** was born in 1988 in Frydek-Mistek. In 2011 he received a Bachelor's degree

from VSB–Technical University of Ostrava, Faculty of Electrical Engineering and Computer Science, Department of Computer Science. Two years later he received a Master's degree in the field of Telecommunications at the Department of Telecommunications. He is currently a Ph.D. student, and he works in the field of optical communications and aging of the optical components.

**Stanislav ZABKA** was born in 1988 in Myjava, Slovakia. In 2010 he received a Bachelor's degree from VSB–Technical University of Ostrava, Faculty of Electrical Engineering and Computer Science, Department of Information and communications technologies. In 2013, he received a Master's degree in the field of Information technologies in the same workplace. In 2016, he will start as a Ph.D. student, and he is currently working as a software developer in an international IT company in the area of energy utilities, distribution processes a communication.

**Vladimir VASINEK** was born in Ostrava. In 1980 he graduated in Physics, specialization in Optoelectronics, from the Science Faculty of Palacky University. He was awarded the title of RNDr. At the Science Faculty of Palacky University in the field of Applied Electronics. The scientific degree of Ph.D. was conferred upon him in the branch of Quantum Electronics and Optics in 1989. He became an associate professor in 1994 in the branch of Applied Physics. He has been a professor of Electronics and Communication Science since 2007. He pursues this branch at the Department of Telecommunications at VSB–Technical University of Ostrava. His research work is dedicated to optical communications, optical fibers, optoelectronics, optical measurements, optical networks projecting, fiber optic sensors, MW access networks. He is a member of many societies - OSA, SPIE, EOS, Czech Photonics Society; he is a chairman of the Ph.D. board at the VSB–Technical University of Ostrava. He is also a member of habitation boards and the boards appointing to professorship.