

## UNEQUAL INPUT VOLTAGES DISTRIBUTION BETWEEN THE SERIAL CONNECTED HALFBRIDGES

R. Ovcarčík<sup>a)</sup>, P. Špánik<sup>a)</sup>, R. Šul<sup>a)</sup>, F. Chimento<sup>b)</sup>

*University of Žilina, the faculty of Electrical Engineering, Department of Electronic and Mechatronics,  
Univerzitná 1, 010 26 Žilina*

*e-mail: Radovan.Ovcarcik@fel.utc.sk*

*DIEES – ARIEL, Department of Electrical, Electronics and Systems Engineering, University of Catania,  
Viale A. Doria 6, 95 125 Catania*

*e-mail: fchimento@diees.unict.it*

**Summary** This paper describes a topology of DC-DC converter consisting in two serial connected half-bridges. Secondary circuit is realized like a conventional full-wave rectifier. The main advantage of this topology is the possibility of dividing the input voltage between the half-bridges. The converter is controlled using the phase-shift modulation, which allows a ZVS operation mode. The voltage unbalance between the inputs causes an important problem of the presented topology. It is necessary to avoid it by the control algorithm, which is described in the text. The practical results show a zero voltage switching technique and the limits of the chosen topology and of the control.

### 1. INTRODUCTION

The serial connection of the half-bridge inverters is usually used because of a necessity of supplying converter by a higher voltage than maximum allowed drain-source one. To obtain a high switching frequency operation is better to use a semiconductor chosen from a lower power category of the semiconductor devices. By the serial or parallel combination of some parts of converters is possible to obtain required power transferred by the system. The exact topology is shown in Fig. 1.

Leakage inductance of the transformer is the most important parasitic component. The energy stored in the leakage inductance can be utilized during a commutation process. Either, in this category of converters a trend is nowadays spread to use the soft commutation techniques. The main reason for this topic is the minimization of the switching losses, which produce substantial interest.

A common problem of the presented topology is the not aligned voltage distribution between the half-bridges. This phenomenon causes the lower maximum allowed voltage of the input. The base reason of existence the voltage unbalancing, as marked above is the one direction transfer of energy stored in the transformer leakage inductances. To reduce this problem is necessary to make a correction of the converter control algorithm, which is described in the next seasons.

### 2. THE OPERATION ANALYSIS

The problem of voltage unbalancing between the half-bridges occurs just when the phase-shift control strategy is applied. Each half-bridge duty-cycle is 50%. Transferred power is changed by the shifting of control pulses between each half-bridge. To describe a principal of operation is necessary to define next simplifications:

- All the components drawn in the schematic are considered to be ideal.
- The output filter is substituted by the constant current source.

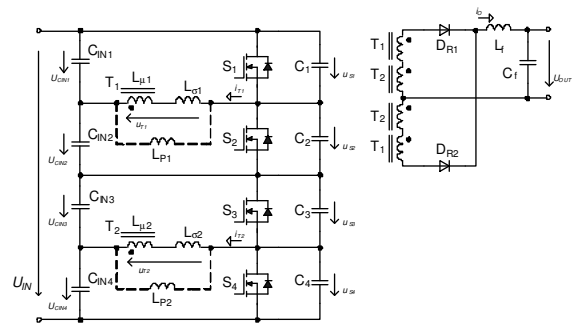

Fig. 1. The topology of the high input voltage converter

A half-period of one cycle consists of five stages, which are described as follow according a Fig. 2.

**Stage 1 ( $t_0 - t_1$ ):** Switches  $S_1$  and  $S_2$  are turned on. The values of the voltages and the currents on transformers are positive. In this meanwhile the power is transferred to the load.

**Stage 2 ( $t_1 - t_2$ ):** This stage starts when the switch  $S_1$  turns off. A resonance between the transformers inductances and the switch output capacities was initialized. At the beginning of the stage the voltage across capacity  $C_1$  was equal to zero. The overcharging of the capacities  $C_1$  and  $C_2$  continues without problems, because a direction of the transformer current  $i_{T1}$  is always right.

**Stage 3 ( $t_2 - t_3$ ):** The stage is initialized when the voltage of the capacity  $C_2$  reaches the zero value. The internal diode  $D_2$  begins to conduct. During the on – state it is possible to turn on the switch  $S_2$  under ZVS condition. Voltage on the  $T_1$  transformer primary side is opposite now. Accordly the sum of the secondary voltages is zero for now and the

power transfer is blocked. Both rectifier diodes conduct because of freewheeling interval. The primary current of the transformer  $T_1$  is decreasing and the change stops, when it reaches the opposite value referred to the output current. This stage finishes when the switch  $S_3$  is turned off.

**Stage 4 ( $t_3 - t_4$ ):** In this stage we can consider two concepts of the interval continuance. If the transformer current is positive and the value is sufficient to provide a complete recharging of capacities  $C_3$  a  $C_4$ , the operation leads to the soft commutation process. In the other case there is not enough energy stored in the leakage and it is impossible to provide a soft commutation process. The shape of this interval depends on the value of the output current. On the secondary side a freewheeling conduction mode remains.

**Stage 5 ( $t_4 - t_5$ ):** The voltage on both transformers is negative after turning on the switch  $S_4$ . The power is transferred through one diode in secondary side. This interval is similar to the first one and the half-period is finished.

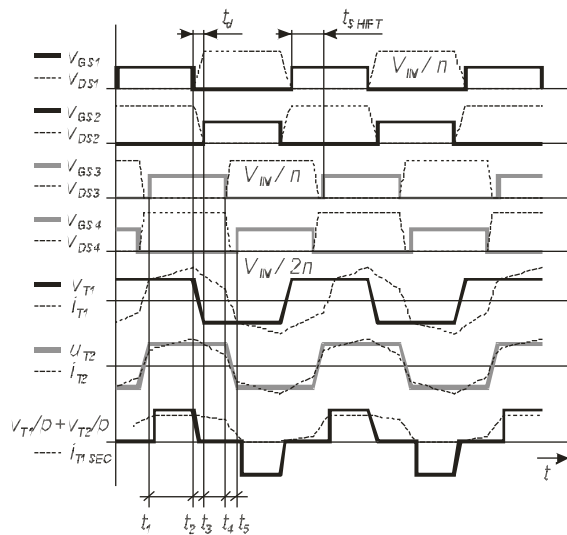

Fig. 2. Main waveforms of the converter controlled by PSM modulation

### 3. THE VOLTAGE UNBALANCE BETWEEN THE HALF-BRIDGES

The voltage unbalance between the serial connected capacitors does not depend only on a capacity tolerance. This kind of unbalancing can appear only during a no-load operation. The input capacitors voltage should be balanced as soon as the converter is loaded. But the reality is different. The most dangerous difference between the voltages on first and second half-bridge appears like a full load mode.

The PSM modulation guaranties equal voltages on the capacities in a frame of one half-bridge. The voltage difference between half-bridges depends on

the output current and actually on phase shift. The leakage inductance of the transformer stores a little energy which is used during the commutation process and causes the voltage unbalancing. The explanation of the process is presented as follow according the schematic in Fig. 1.

In the end of the power transfer stage, which is done by switch  $S_1$  and  $S_3$  a new combination of switches –  $S_2$  and  $S_3$  follows. When the switch  $S_2$  is turned on, the current through both transformers follows a demarcated direction. If there is not the leakage inductance in the transformer, its currents change immediately to a value, which is assigned by the actually magnetizing current. The ideal transformer means the zero energy stored in the leakage. In this ideal case cannot ensue the voltage unbalancing. However, a designer should calculate with the real transformer, which stores some energy in the leakage. During the intervals, when the transformers work one against the other, the energy from the leakage is transferred to the capacity of the half-bridge, which is not delayed. For example, after turning on the switch  $S_2$  the current  $i_{T1}$  charges the capacity  $C_{IN2}$ . In the other half-bridge is capacity  $C_{IN3}$  discharged by the current  $i_{T2}$ . The next interval is active. Energy is transferred by both transformers. Then after exchange the switch  $S_2$  by  $S_1$  is the capacity  $C_{IN1}$  charged again and the energy from the capacity  $C_{IN4}$  is taken away. The energy statement is shown in the Tab. 1. The sign means the drop or growth of the energy and in parentheses is inscribed the source of the energy.

Tab. 1. The energy balance between the half-bridges

Switch "on"	$C_{IN1}$	$C_{IN2}$	$C_{IN3}$	$C_{IN4}$
$S_1, S_3$	- (load)	+ (source)	- (load)	+ (source)
$S_2, S_3$	+ (source)	+ (leak.)	- (leak.)	+ (source)
$S_2, S_4$	+ (source)	- (load)	+ (source)	- (load)
$S_1, S_4$	+ (leak.)	+ (source)	+ (source)	- (leak.)
<b>balance</b>	<b>+</b>	<b>+</b>	<b>-</b>	<b>-</b>

In a real circuit is important to consider the parasitic resistances of the switches, input capacities and the transformers winding. During a passive interval a transient effect runs, which is defined by the equations (1) and (2). The equivalent resistance  $R_e$  (3) consist of the resistances listed bellow.

$$i_{T1}(t) = i_{T1}(0) \cdot e^{-\frac{R_e \cdot t}{L_\sigma}} + i_{\mu 1} \quad (1)$$

$$i_{T2}(t) = i_{T2}(0) \cdot e^{-\frac{R_e \cdot t}{L_\sigma}} + i_{\mu 2} \quad (2)$$

$$R_e = 2 \cdot R_{DS(on)} + 2 \cdot R_{CIN} + 2 \cdot R_P + 4 \cdot R_S \cdot p^2 + 2 \cdot R_{DUSM} \cdot p^2 \quad (3)$$

$$L_\sigma = 2L_{\sigma p} + L_{\sigma s} \cdot p^2 \quad (4)$$

$i_{\mu 1}, i_{\mu 2}$	- magnetizing current
$R_{CIN}$	- serial resistance of the input capacity
$R_{DS(on)}$	- on-resistance of the switch
$R_P$	- primary winding resistance
$R_S$	- secondary winding resistance
$R_{DUSM}$	- rectifier diode resistance
$p$	- ratio of the transformer

The voltage on one half-bridge depends on output current and the actual phase shift, as was presented above.

#### 4. A MINIMIZATION OF THE INPUT VOLTAGE UNBALANCING BY THE CONTROL ALGORITHM

The primary request of the presented topology is the possibility to supply it from the high voltage source. Unequal distribution of the input voltage makes the converter ineffective. Moreover, the converter should work in a zero voltage switching mode. In the reference [2] is presented a method, which changes each period the commands from one half-bridge to the second one and backward. This solution can cause in the frame of each period the hard commutation process.

The other possibility is an interleaving of the commands done not in every period, but every time after passing a couple of switching periods. For example, the control circuit changes the commands for each half-bridge every 64 periods. This means that the hard commutation process occurs just 64 times less than commonly. Switching algorithm is described in Fig. 3.

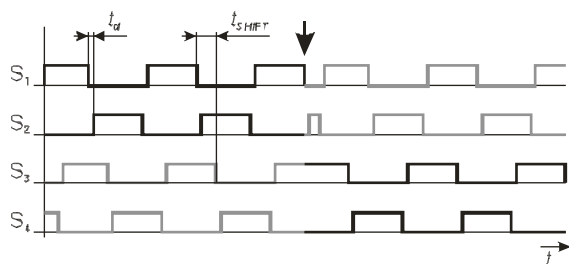

Fig. 3. Replacing of the drive commands for each half-bridge

Using this control algorithm, the energy transferred from one half-bridge to the other is balanced. Tab. 2 shows a zero energy balance. The voltage on one half-bridge is changing in one direction during few of the periods. Then, after the replacing the switching impulses, the voltage across the same capacity starts to change in opposite direction. A designer of the converter can choose the algorithm by which the commands are interchanged.

Tab. 2. Energy balance after interchanging the driving impulses for the half-bridges

Switch "on"	$C_{IN1}$	$C_{IN2}$	$C_{IN3}$	$C_{IN4}$
S <sub>1</sub> , S <sub>3</sub>	- (load)	+ (source)	- (load)	+ (source)
S <sub>2</sub> , S <sub>3</sub>	+ (source)	+ (leak.)	- (leak.)	+ (source)
S <sub>2</sub> , S <sub>4</sub>	+ (source)	- (load)	+ (source)	- (load)
S <sub>1</sub> , S <sub>4</sub>	+ (leak.)	+ (source)	+ (source)	- (leak.)
<b>bal. 1</b>	<b>+</b>	<b>+</b>	<b>-</b>	<b>-</b>
S <sub>1</sub> , S <sub>3</sub>	- (load)	+ (source)	- (load)	+ (source)
S <sub>1</sub> , S <sub>4</sub>	- (leak.)	+ (source)	+ (source)	+ (leak.)
S <sub>2</sub> , S <sub>4</sub>	+ (source)	- (load)	+ (source)	- (load)
S <sub>2</sub> , S <sub>3</sub>	+ (source)	- (leak.)	+ (leak.)	+ (source)
<b>bal. 2</b>	<b>-</b>	<b>-</b>	<b>+</b>	<b>+</b>
<b>Result</b>	<b>0</b>	<b>0</b>	<b>0</b>	<b>0</b>

One of them was already presented – interchanging every couple of switching periods. The other possibility is changing the number of the periods, which depends on the load current or the half-bridge voltage. The principal diagram is shown in Fig. 4.

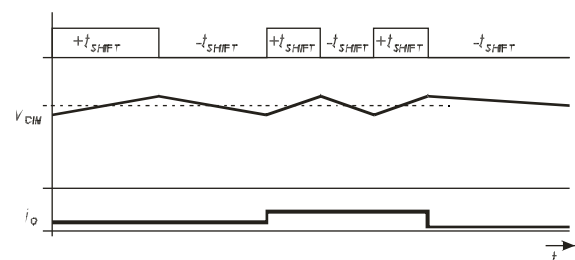

Fig. 4 The ripple of the input capacity voltage depending on the load current and interleaving frequency

The third method can be based on sensing the voltage on one half-bridge. The frequency of commands changing depends on the chosen hysteresis.

#### 5. EXPERIMENTAL RESULTS

The converter is designed for traction application, like an auxiliary converter for some additional circuits in a train wagon, for example the battery charger. The main design parameters are the following:

$$\begin{aligned}
 P &= 1000\text{W} \\
 V_{IN} &= 700\text{V} \\
 V_{OUT} &= 24\text{V} \\
 f_{SW} &= 100\text{kHz}
 \end{aligned}$$

The converter topology allows using the soft commutation process. The parameters of the passive elements are optimized for full load range ZVS operation. This kind of optimization is not a topic of this paper. The results show the soft commutation process and also the voltage across switches on the half-bridges.

In Fig. 5 measured waveforms on switch S<sub>4</sub> during no-load operation are described. The lowest

waveform respects the voltage  $v_{GS}$ . Driving impulse comes after the voltage  $v_{DS}$  reach a zero volt. Fig. 6 shows the same situation in full-load mode. In both is possible to see the ZVS commutating process. The switch capacity is charged by the transformers current. The waveforms on the transformer are shown in Fig. 7.

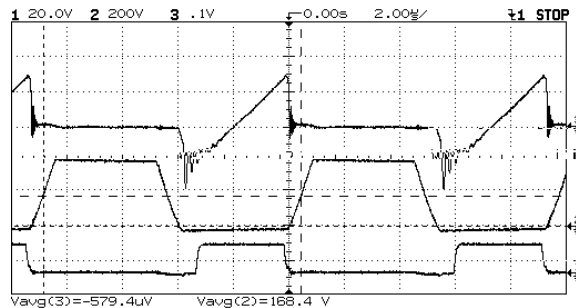

Fig. 5. The waveforms on the switch  $S_4$  – zero load  
- ch1 -  $v_{GS}$ , ch2 -  $v_{DS}$ , ch3 -  $i_D$  – 2 A/div

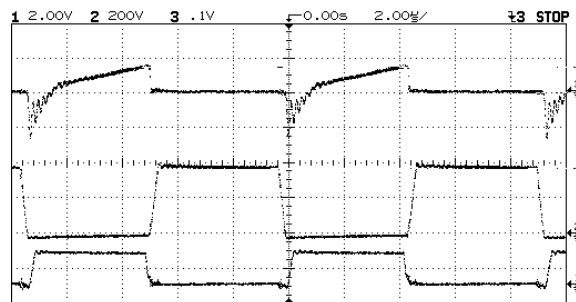

Fig. 6. The waveforms on the switch  $S_4$  – full load  
- ch1 -  $v_{GS}$ , ch2 -  $v_{DS}$ , ch3 -  $i_D$  – 10 A/div

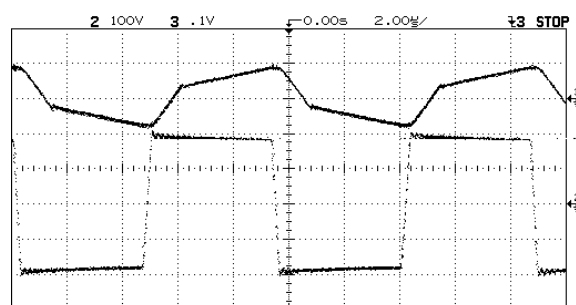

Fig. 7. The waveforms on the transformer  $T_1$  – full load  
- ch2 -  $v_{T1}$ , ch3 -  $i_{T1}$  – 10 A/div

After the replacing of driving commands, the length of each impulse is changed. For a short time it is not 50% like during a steady state. The magnetizing current obtains a DC component and changes the initial conditions of commutation process. This is the reason, why the hard switching process can occur. The practical result is presented in Fig. 8. The amplitude of drain current oscillations depends on the output switch capacity. Auxiliary capacities parallel connected can produce much

more noise, so they are not connected in the real circuit.

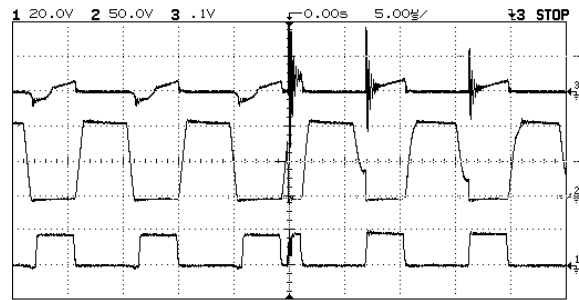

Fig. 8. The waveforms after replacing of the drive commands  
- ch1 -  $v_{GS}$ , ch2 -  $v_{DS}$ , ch3 -  $i_D$  – 5 A/div

## Acknowledgement

This work was partly financially supported by VEGA grant no. 1/3123/06 and the project no. 2003 SP 51/028 09 00/028 09 05-2003 “Improvement of quality and exploitation of electrical energy for traction and general applications” of the Ministry of Education of Slovak Republic.

## REFERENCES

- [1] MOHAN, UNDELAND, ROBINS: *Power Electronics. Converters Application and Design*. John Wiley & Sons Inc., Singapore, 1989.
- [2] PINHEIRO, J. R. - BAGGIO, J. E.: *Isolated Interleaved-Phase-Shift-PWM dc-dc ZVS Converters*. Conference Record of the IEEE Industry Applications Conference. USA 2000, VOL 4, pages 2383-2388.
- [3] DOBRUCKÝ, B. – ŠPÁNIK, P.: *Modeling and simulation analysis of power semiconductor structures*. Scientific monograph. EDIS, University of Žilina, December 1999.
- [4] DUDRÍK, J.: *Indirect DC-to-DC Converter for Arc welding*. EDPE '96 Proceedings of the Annual Conference, High Tatras, Volume 2, 1996, pp. 333 – 336.
- [5] FEŇO, I: *Analysis and synthesis of switching techniques of IGBT and verification on the serial resonant converter*. Dissertation thesis. Žilina, September 2003.
- [6] KOVÁČOVÁ, I. – KOVÁČ, D.: *Power transistors MOSFET and IGBT*. ALFA, Košice 1996.